

## MH-100 Specification

Ni-MH Button Cell

### Specification

Norminal Capacity	110mAh
Weight	4.4g
Voltage	1.2V
Charge Current	11mA
Trickle Charge Current	3.3 – 5.5mA
Charge Time	14-16 Hours
Discharge Current	22mA
Discharge Time	5 Hours
Battery Life	≥ 400 Cycles
(IEC/CEI61951-2:2001. 4.4)	

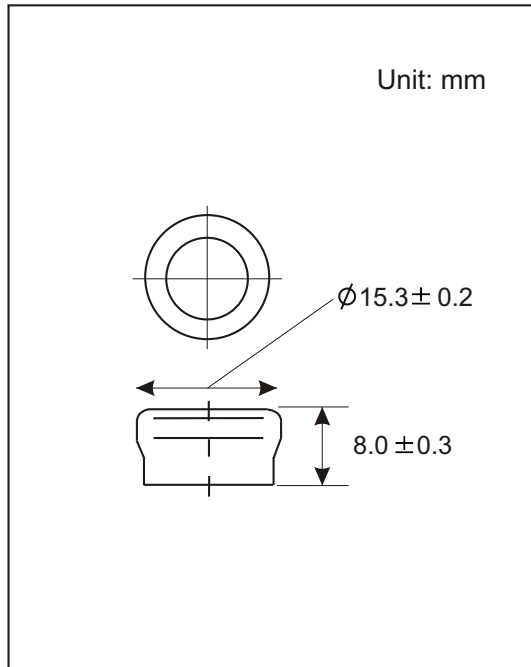

**TYPICAL CHARGE CURVE (11mA)**

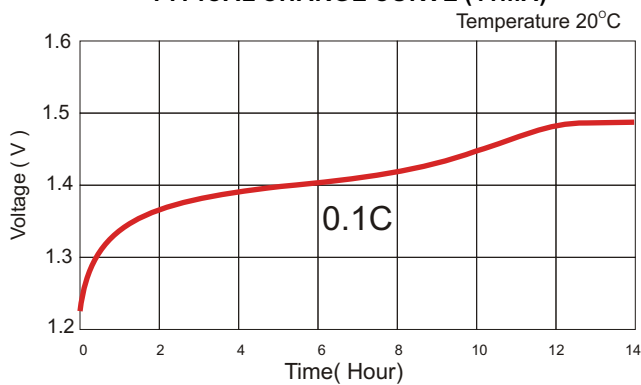

**TYPICAL DISCHARGE CURVE (22mA)**

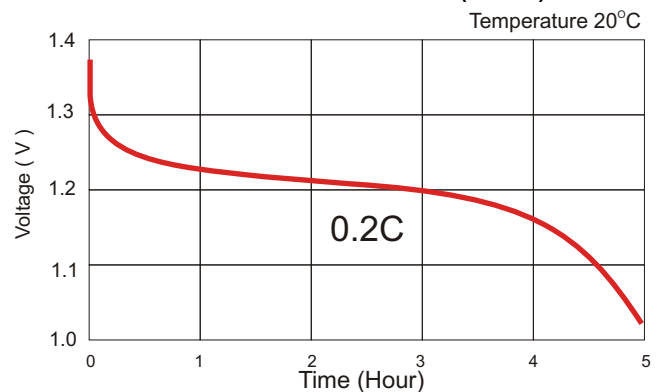

**Discharge curve at various temperature (22mA)**

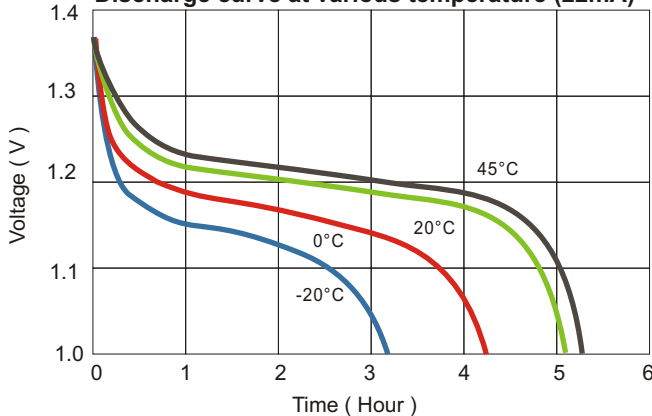

**Self discharge rate at various temperatures**

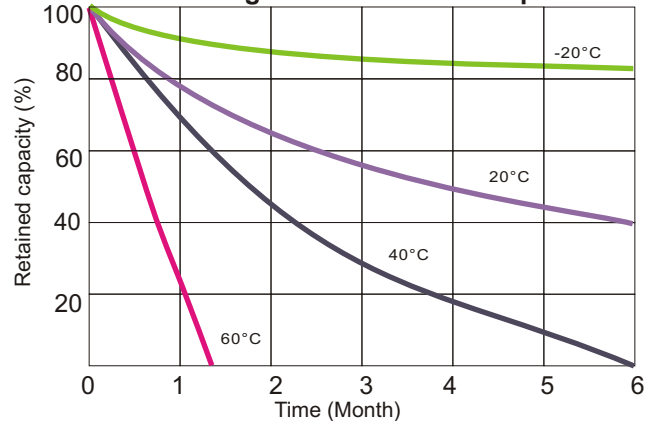

\*\*Note: The data in this document are for descriptive purposes only and subject to change without prior notice.