

MH-1000AAH Specification

NiMH Cylindrical Battery

Size: AAA IEC: KR11/45

Typical Characteristics

Model: MH-1000AAH		
Specifications		
Nominal Voltage (V)		1.2V
Capacity	Typical (mAh)	950
	Minimum (mAh)	900
Dimension	Diameter (mm)	10.5 ⁺⁰ _{-0.7}
	Height (mm)	44.5 ⁺⁰ _{-1.5}
Charging	Standard	90mA(0.1C ₅) x 16 hrs
	Rapid	450mA(0.5C ₅) x 2.3 hrs -ΔV = 5mV
	Trickle	45mA(0.05C ₅) x 48 hrs
Operating Temperature (°C)	Standard Charging	0 ~ 45°C
	Rapid Charging	10 ~ 40°C
	Discharging	-20 ~ 60°C
	Storage	-20 ~ 35°C
Service Life	>500 cycles (IEC standard)	
Internal Resistance	40m Ohm (upon fully charged)	
Weight	Approx. 13g	
Cuff-off Voltage (V)	1.00	

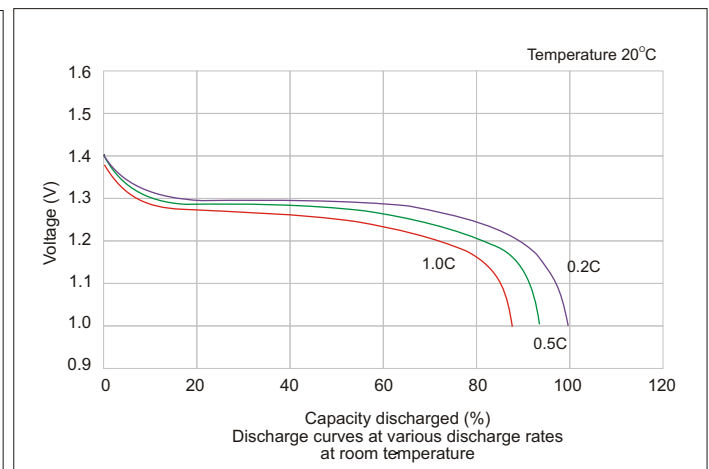
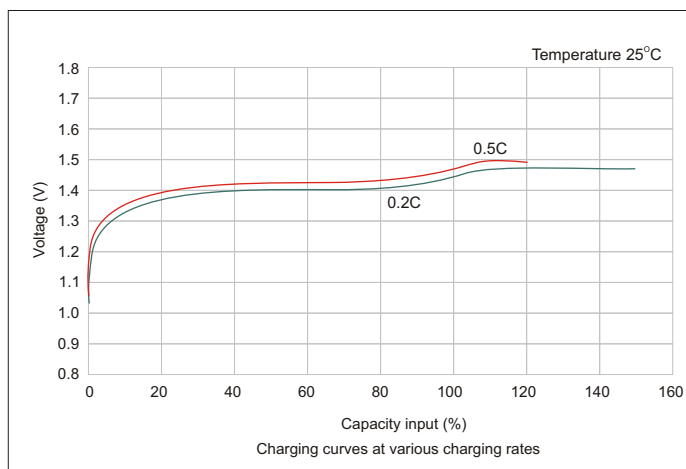
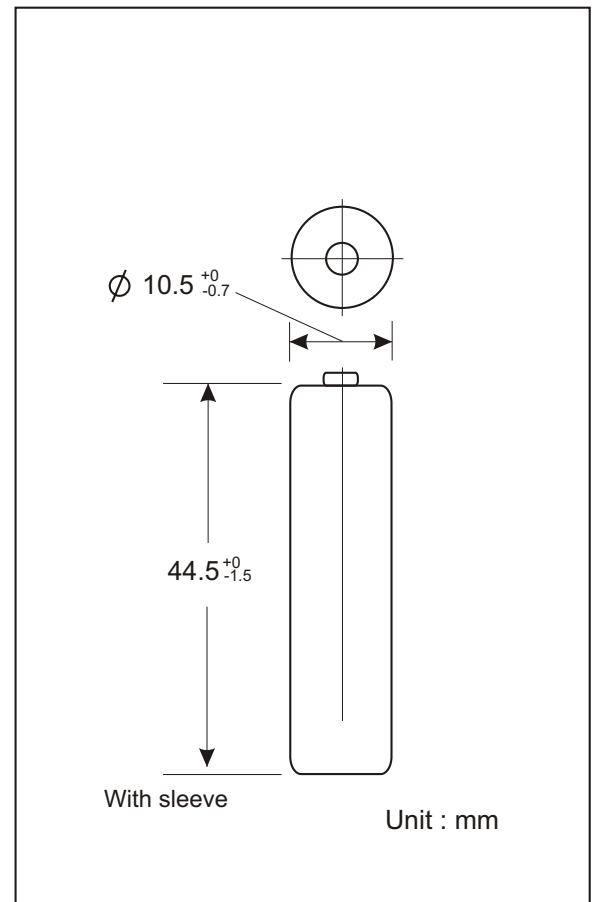

**Note: The data in this document are for descriptive purposes only and subject to change without prior notice.