

MH-12 Specification

Ni-MH Button Cell

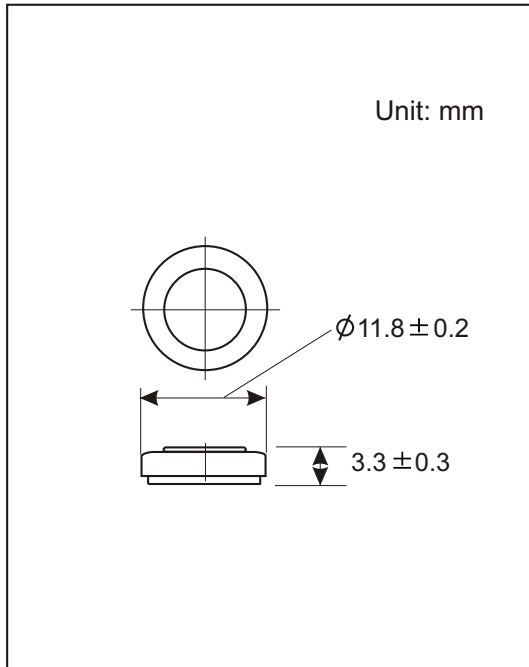

Specification

Norminal Capacity	18mAh
Weight	1.3g
Voltage	1.2V
Charge Current	1.8mA
Trickle Charge Current	0.5 – 0.9mA
Charge Time	14-16 Hours
Discharge Current	3.6mA
Discharge Time	5 Hours
Battery Life (IEC/CEI61951-2:2001. 4.4)	≥ 400 Cycles

TYPICAL CHARGE CURVE (1.8mA)

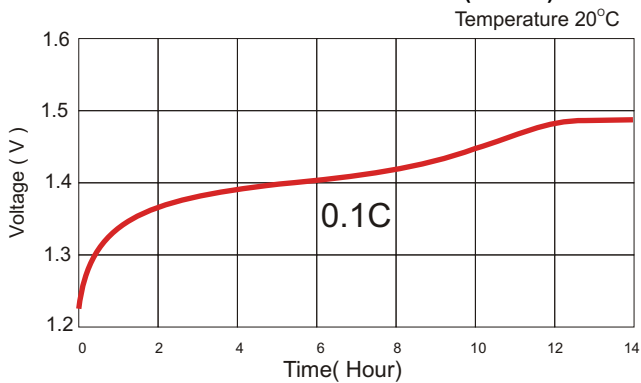

TYPICAL DISCHARGE CURVE (3.6mA)

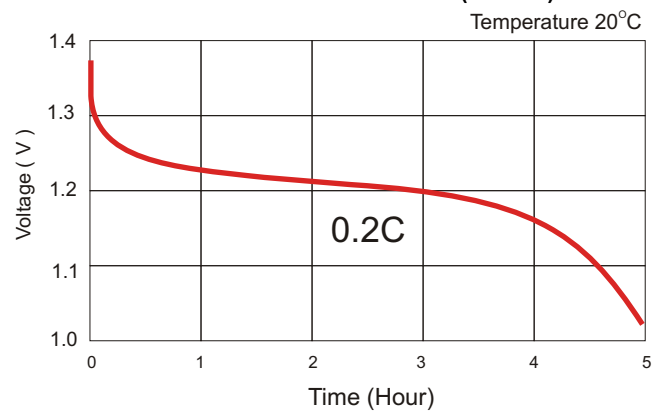

Discharge curve at various temperature (3.6mA)

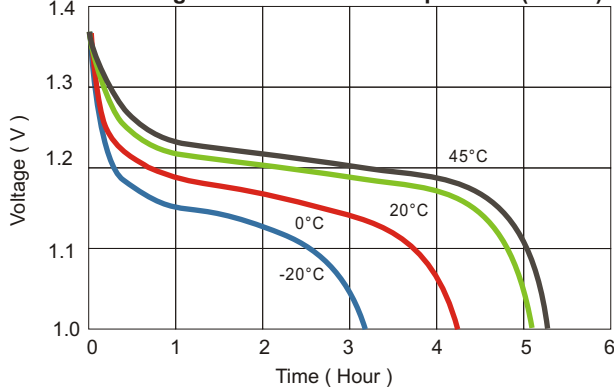

Self discharge rate at various temperatures

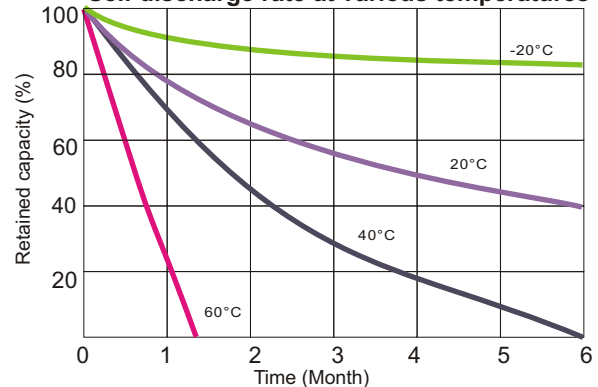

**Note: The data in this document are for descriptive purposes only and subject to change without prior notice.