

MH-170 Specification

Ni-MH Button Cell

Specification

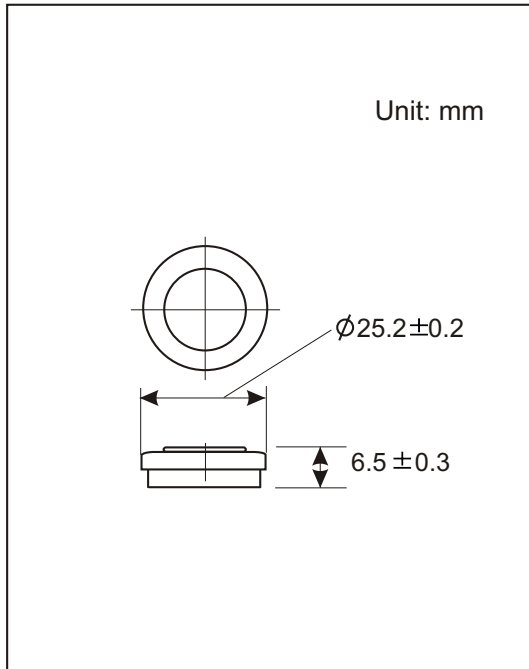

Norminal Capacity	230mAh
Weight	10.2g
Voltage	1.2V
Charge Current	23mA
Trickle Charge Current	6.9 – 11.5mA
Charge Time	14-16 Hours
Discharge Current	46mA
Discharge Time	5 Hours
Battery Life (IEC/CEI61951-2:2001. 4.4)	≥ 400 Cycles

TYPICAL CHARGE CURVE (23mA)

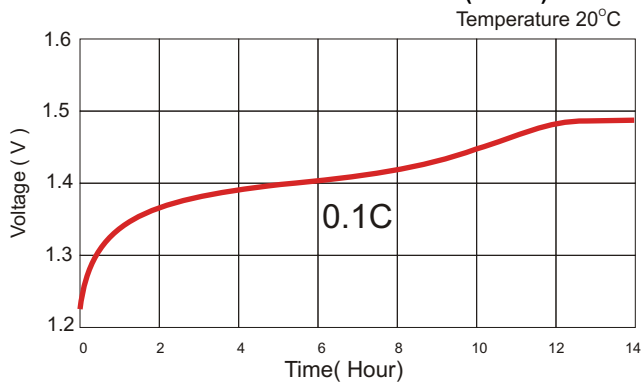

TYPICAL DISCHARGE CURVE (46mA)

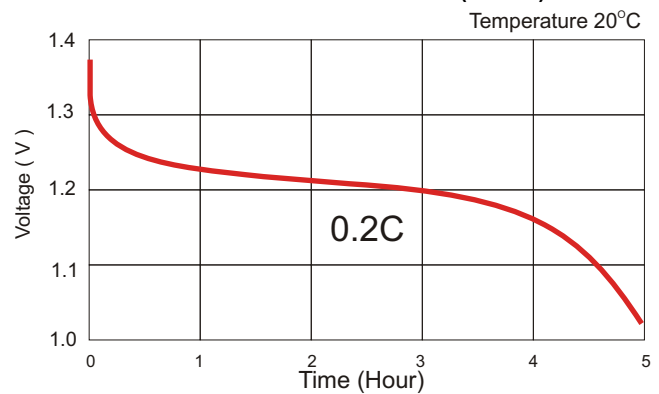

Discharge curve at various temperature (46mA)

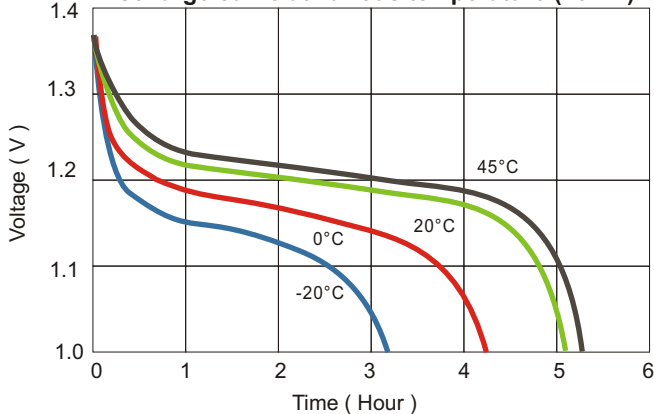

Self discharge rate at various temperatures

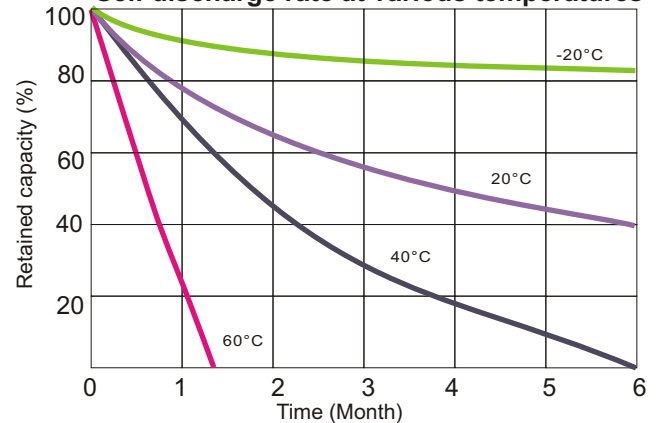

**Note: The data in this document are for descriptive purposes only and subject to change without prior notice.