

MH-60 Specification

Ni-MH Button Cell

Specification

Norminal Capacity	80mAh
Weight	3.5g
Voltage	1.2V
Charge Current	8mA
Trickle Charge Current	2.4 – 4mA
Charge Time	14-16 Hours
Discharge Current	16mA
Discharge Time	5 Hours
Battery Life (IEC/CEI61951-2:2001. 4.4)	≥ 400 Cycles

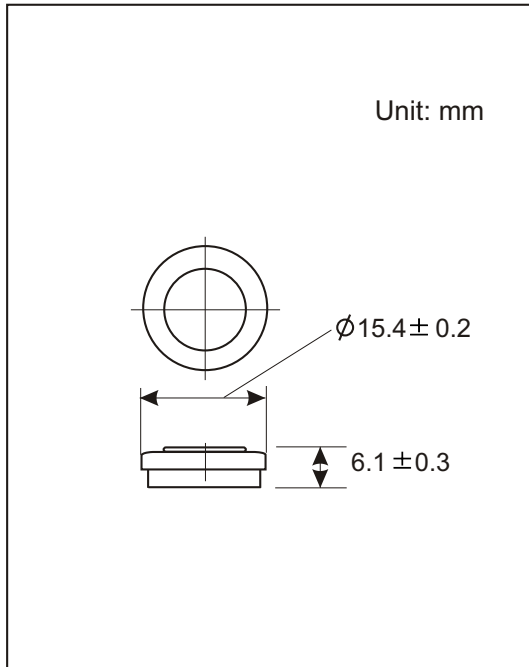

TYPICAL CHARGE CURVE (8mA)

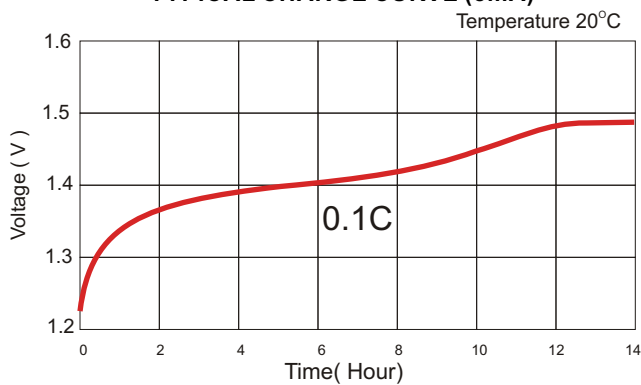

TYPICAL DISCHARGE CURVE (16mA)

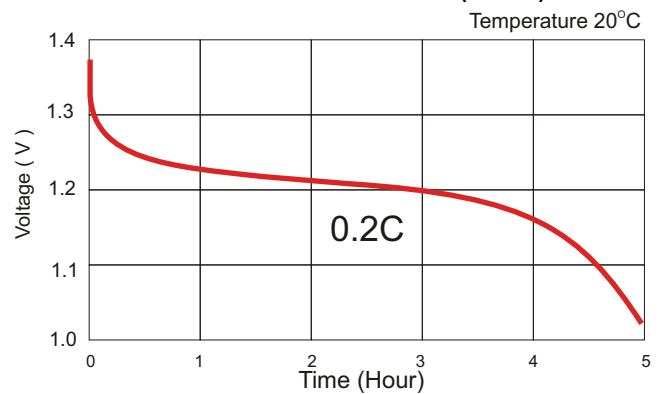

Discharge curve at various temperature (16mA)

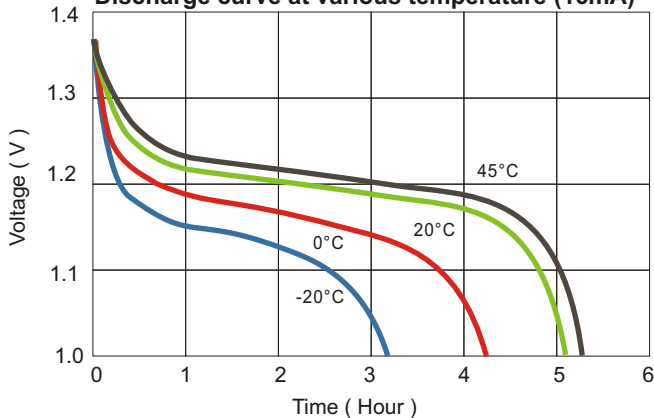

Self discharge rate at various temperatures

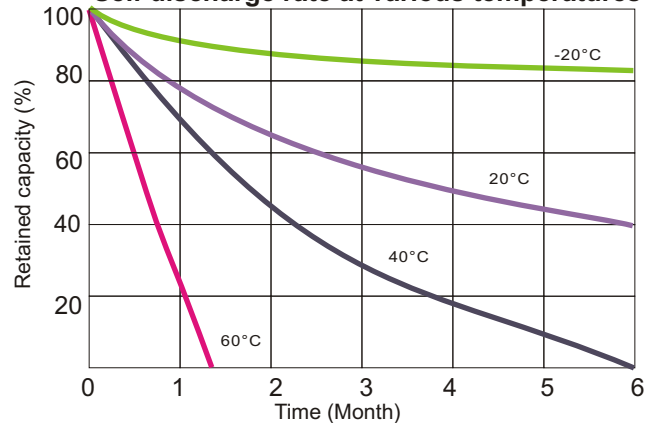

**Note: The data in this document are for descriptive purposes only and subject to change without prior notice.