

MH-800AAH Specification

NiMH Cylindrical Battery

Size: AAA IEC: KR11/45

Typical Characteristics

Model: MH-800AAH	
Specifications	
Nominal Voltage (V) 1.2V	
Capacity	Typical (mAh) 800
	Minimum (mAh) 750
Dimension	Diameter (mm) $10.5^{+0}_{-0.7}$
	Height (mm) $44.5^{+0}_{-1.5}$
Charging	Standard 75mA(0.1C ₅) x 16 hrs
	Rapid 375mA(0.5C ₅) x 2.3 hrs -ΔV = 5mV
	Trickle 37.5mA(0.05C ₅) x 48 hrs
Operating Temperature (°C)	Standard Charging 0 ~ 45°C
	Rapid Charging 10 ~ 40°C
	Discharging -20 ~ 60°C
	Storage -20 ~ 35°C
Service Life	>500 cycles (IEC standard)
Internal Resistance	40m Ohm (upon fully charged)
Weight	Approx. 12g
Cuff-off Voltage (V)	1.00

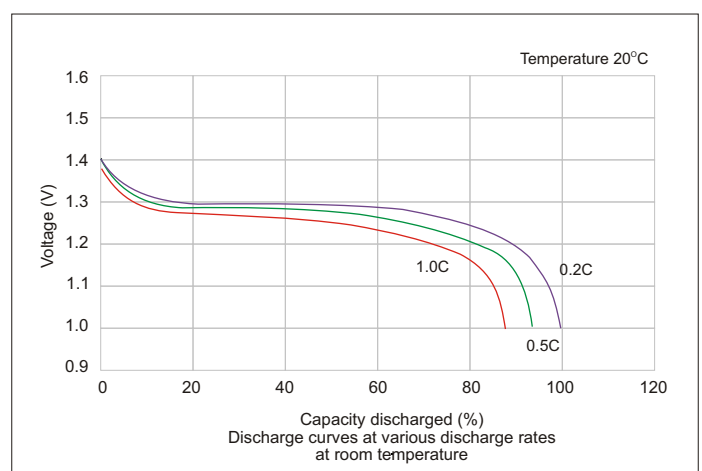
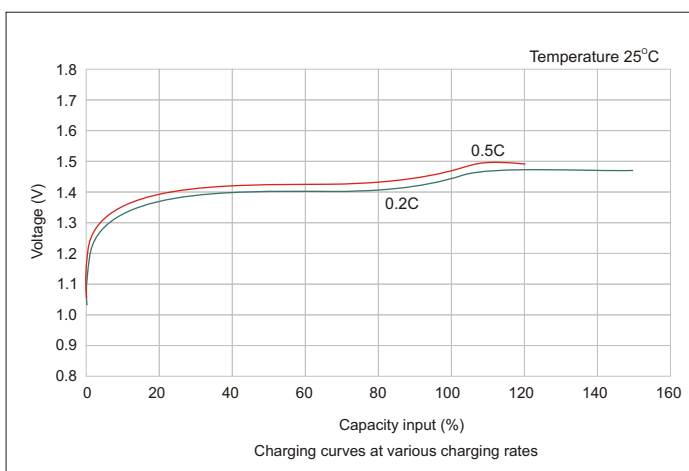
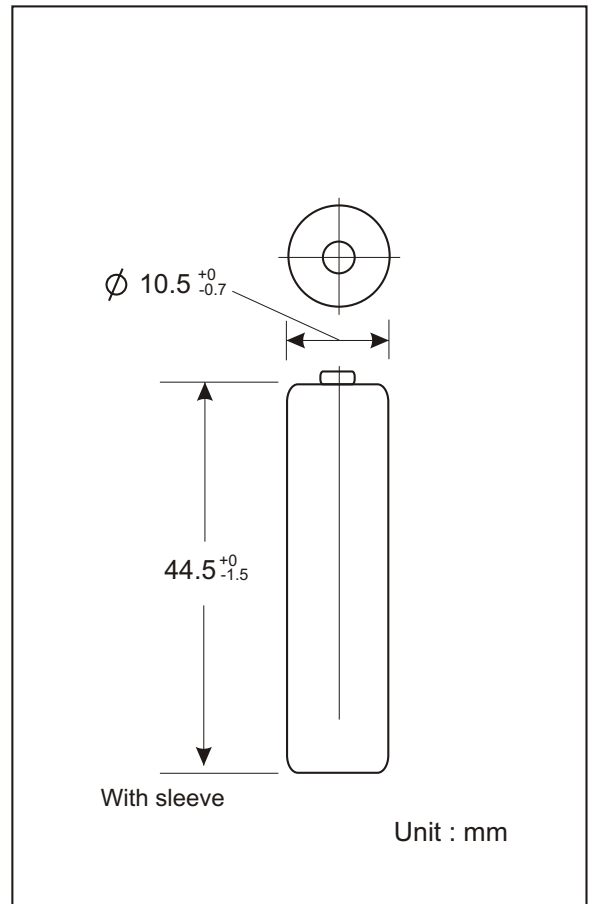

**Note: The data in this document are for descriptive purposes only and subject to change without prior notice.