

WR34615 Specification

Primary Lithium Sulfur Dioxide
2.9V, 7800mAh

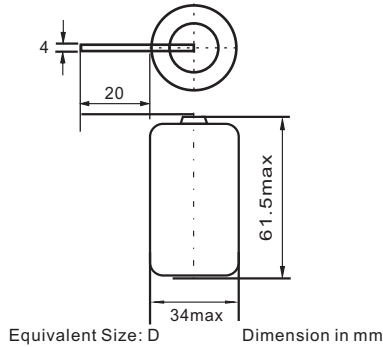

Available Terminations	
-/P *	Axial Pin
-/T /PT2 *	Radial Pin
-/PT /TP*	Polarized Tab
(*) : Reference to standard terminals for single lithium	

Electrical characteristics

- **Nominal Capacity** 7800mAh
Stored for one year or less at 100mA, 20°C, 2.0V cut-off
- **Rated Voltage** 2.9V
- **Max. Recommended Continuous Current** 4000mA
Current value is determined to be the level at which the nominal capacity is obtained with an end voltage of 2.0V at 20°C
- **Max. Pulse Current** 6000mA
Current value is obtaining 2.0V cell voltage when pulse is applied for 15 seconds at 50% discharge depth at 20°C
- **Storage (Recommended Max. Temperature)** 30°C
- **Operating Temperature Range** -55°C~ +65°C
- **Approximate Weight** 90g

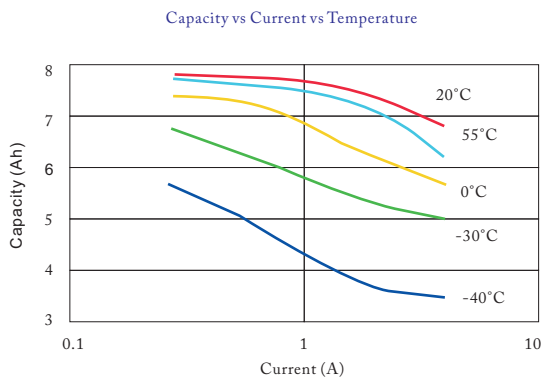
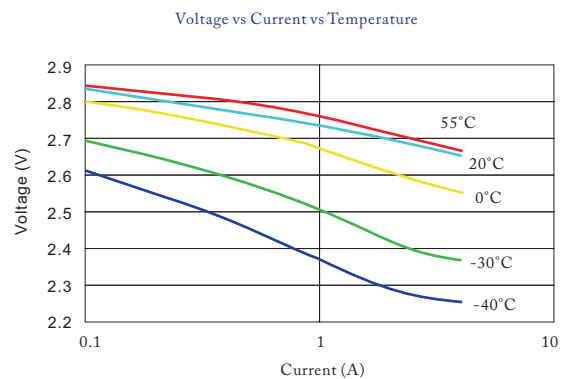
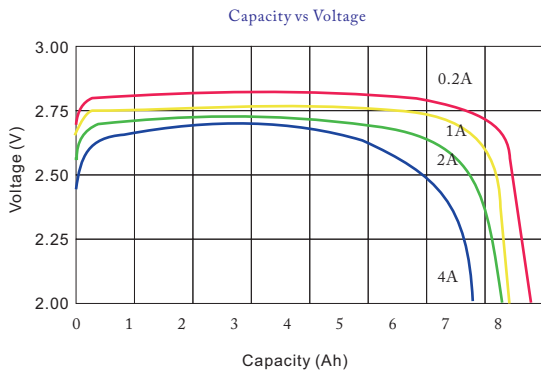

WARNING: Risk of fire and burn. Do not recharge, disassemble, heat above 100°C or incinerate.
Do not mix fresh batteries with used batteries.

**Note: The data in this document are for descriptive purposes only and subject to change without prior notice.